

# Model 53X



- Cast construction in stainless steel
- Conforming to the PED, CE-marked
- Sizes 1" to 4"

## FEATURES

- Dynamic sealing design for long life
- Easy-to-operate lever handle—no gear box required
- Unique seat and seal design requires no adjustments
- Standard pressure equalizing kit on 3" and 4" models
- PTFE-seats for longer service life
- Foot pads for rock solid installation
- Double-stem O-rings for positive sealing
- Easy to access body vent valve
- Plugs in each basket cover
- Piston seal strainer basket cover
- Easy access for diverter cartridge removal
- 316 stainless steel ball design
- DIN and ANSI flanged end connections
- Designed to 16 bar, 120°C
- Bolted cover
- Machined basket seat with O-ring seal
- Large capacity 316 stainless steel baskets, perforated or mesh
- Gasket material FPM
- Bottom drain port
- Basket perforations from  $\frac{1}{32}$ " to  $\frac{1}{2}$ "
- Basket mesh from 20 to 400 (900-25 $\mu$ m)

## OPTIONS

- Gauges/vent valves
- Pressure differential gauge and switches (for 3" and 4" models only)

Specifically designed for conformance in the European market, the model 53X duplex cast manual strainer complements Eaton's range of manual pipeline strainers.

The model 53X is CE-marked to Pressure Equipment Directive (PED) and is compliant with the EN13445 and AD 2000 pressure vessel codes.

Also the model 53X pipeline strainers provide bypass-free filtration to protect process equipment in most demanding applications, including chemical, petrochemical and water pipelines that cannot be temporarily shut down for strainer basket cleaning or changeout.

The new duplex 53X strainer range features the same connection dimensions as Eaton's legacy 53BTX models, enabling simple upgrades and open up the use in new applications requiring CE-stamped strainers.

For ease of use, the new duplex 53X models use the same strainer basket range in various retention ratings but

features improved sealing with an additional O-ring underneath the basket.

**Continuous operation:**  
The Eaton Model 53X duplex basket strainer can operate continuously, eliminating the need to shut down processes for cleaning of strainers. When the first basket is full, a unique flow diverter cartridge shifts flow to a second basket to permit removal and cleaning with no interruption to operations.

An external pressure equalizing kit is foreseen as standard on all 3" and 4" models for an easier switch-over process.

Draining the unused chamber is easy. Remove the hex bolts and the lid can be lifted without requiring special tools. The unique flow diverter cartridge assures minimal, if any fluid bypass into the out-of-service chamber. It features a dynamic sealing system that ensures exceptionally long seat life and positive sealing. Manual internal or external ball support adjustments are not necessary.



Powering Business Worldwide

# Model 53X Duplex Basket Strainer

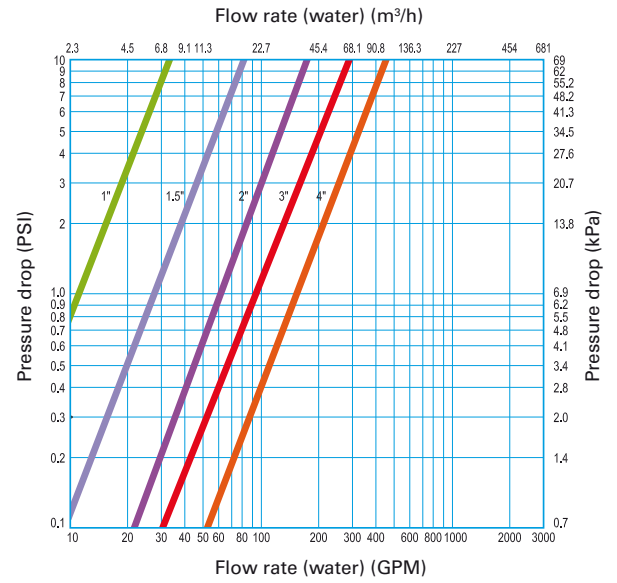
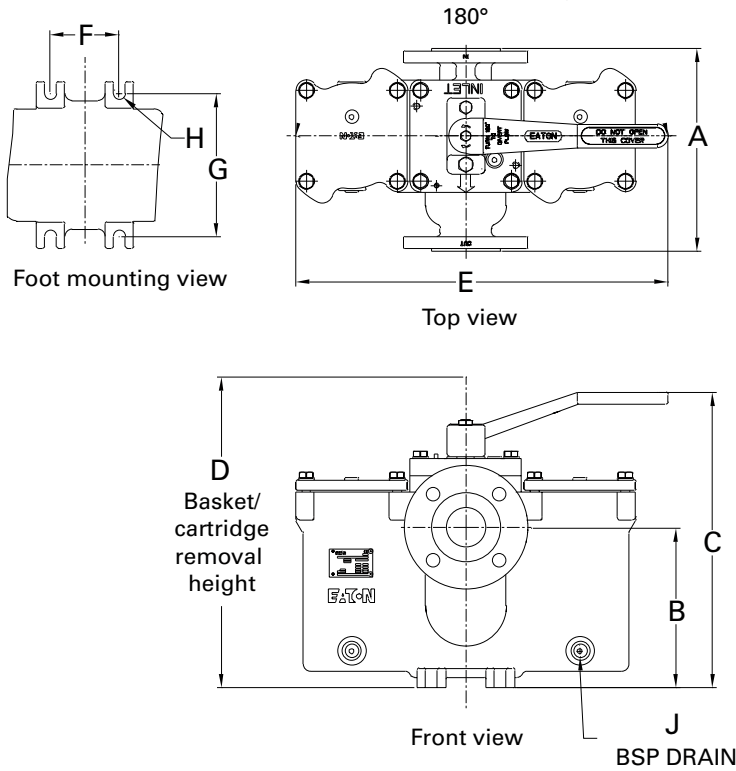

## Flanged Model 53X dimensions (in/mm)

Dimensions and weights are for reference only. Contact Eaton for certified drawings.  
Additional connections G 1/4 inch for differential pressure measurement available on the housing.

Nominal size	A	B	C	D	E	F	G	H	I	Net weight (kg)
1 / DN 25	6.88 / 175	5 / 127	10.55 / 268	16.24 / 413	13.59 / 345	3.26 / 83	4.17 / 106	0.38 / 10	¼	20
1½ / DN 40	9.37 / 238	7 / 178	12.9 / 328	19.77 / 500	14.4 / 366	3.25 / 83	5.52 / 140	0.38 / 10	¼	34
2 / DN 50	10.63 / 270	8.38 / 213	15.5 / 397	25.13 / 638	19.57 / 497	3.62 / 92	7.5 / 190	0.63 / 16	¼	64
3 / DN 80	13.5 / 343	8.87 / 225	18.73 / 477	30.63 / 778	23.1 / 587	3.62 / 92	8 / 203	0.63 / 16	¼	119
4 / DN 100	16 / 406	12 / 304	21.08 / 535	35.56 / 903	26.8 / 681	6.5 / 165	8.98 / 228	0.69 / 17	¼	232

## Model 53X C<sub>v</sub> factors\*

Size	Value
1"	11
1½"	27
2"	62
3"	94
4"	154

\* For water with clean, perforated basket

**North America**  
18684 Lake Drive East  
Chanhassen, MN 55317  
Toll Free: +1 800-656-3344  
(North America only)  
Tel: +1 732-212-4700

**Greater China**  
No. 7, Lane 280,  
Linhong Road  
Changning District, 200335  
Shanghai, P.R. China  
Tel: +86 21 2899-3687

**Europe/Africa/Middle East**  
Auf der Heide 2  
53947 Nettersheim, Germany  
Tel: +49 2486 809-0  
Friedensstraße 41  
68804 Altlussheim, Germany  
Tel: +49 6205 2094-0

**Asia-Pacific**  
100G Pasir Panjang Road  
#07-08 Interlocal Centre  
Singapore 118523  
Tel: +65 6825-1620

An den Nahewiesen 24  
55450 Langenlonsheim, Germany  
Tel: +49 6704 204-0

For more information, please  
email us at [filtration@eaton.com](mailto:filtration@eaton.com)  
or visit [www.eaton.com/filtration](http://www.eaton.com/filtration)

© 2024 Eaton. All rights reserved. All trademarks and registered trademarks are the property of their respective owners. All information and recommendations appearing in this brochure concerning the use of products described herein are based on tests believed to be reliable. However, it is the user's responsibility to determine the suitability for his own use of such products. Since the actual use by others is beyond our control, no guarantee, expressed or implied, is made by Eaton as to the effects of such use or the results to be obtained. Eaton assumes no liability arising out of the use by others of such products. Nor is the information herein to be construed as absolutely complete, since additional information may be necessary or desirable when particular or exceptional conditions or circumstances exist or because of applicable laws or government regulations.